



Designated according to The Construction Products (Amendment etc.) (EU Exit) Regulations 2020

UK Technical Assessment	UKTA-0836-22/6408 of 12/10/2022
Technical Assessment Body issuing the UK Technical Assessment:	British Board of Agrément
Trade name of the construction product:	Liebig Superplus self-undercutting anchor
Product family to which the construction product belongs:	Torque-controlled self undercutting anchor, made of galvanised or stainless steel, for use in concrete: sizes M8, M12 and M16.
Manufacturer:	EJOT Baubefestigungen GmbH In der Stockwiese 35 57334 Bad Laasphe Germany
Manufacturing plant(s):	EJOT Plant 14
This UK Technical Assessment contains:	21 pages including 10 Annexes which form an integral part of this assessment
This UK Technical Assessment is issued in accordance with The Construction Products (Amendment etc.) (EU Exit) Regulations 2020 on the basis of:	UKAD 330232-01-0601 <i>Mechanical Fasteners for Use in Concrete Products</i>

Communication of this UK Technical Assessment, including transmission by electronic means, shall be in full. However, partial reproduction may be made with the written consent of the British Board of Agrément. Any partial reproduction must be identified as such.

1 Technical description of the product

The Liebig Superplus⁽¹⁾ self-undercutting anchor in the sizes of M8, M12 and M16 is an anchor manufactured from of galvanized or stainless steel, which is placed into a drilled hole and anchored by torque controlled expansion.

The illustration and the description of the product are given in Annexes A.

(1) Liebig Superplus is a registered trademark

2 Specification of the intended use(s) in accordance with the applicable UK Assessment Document (hereinafter UKAD)

The performances given in Section 3 are only valid if the anchor is used in compliance with the specifications and conditions given in Annexes B.

The provisions made in this UK Technical Assessment are based on an assumed working life of the anchor of 50 years. The indications given on the working life cannot be interpreted as a guarantee given by the producer, but are to be regarded only as a means for choosing the right products in relation to the expected economically reasonable working life of the works.

3 Performance of the product and references to the methods used for its assessment

3.1 Mechanical resistance and stability (BWR 1)

Essential characteristic	Performance
Characteristic tension resistance for static and quasi-static action	See Annexes C1, C2
Characteristic shear resistance for static and quasi-static action	See Annexes C3, C4
Displacements under static and quasi-static action	See Annexes C8, C9
Characteristic resistance for Seismic Performance Category C1 and C2 Displacements for Seismic Performance Category C2	See Annex C10

3.2 Safety in case of fire (BWR 2)

Essential characteristic	Performance
Reaction to fire	Anchorage satisfy requirements for Class A1
Characteristic tension resistance under fire	See Annexes C5, C6
Characteristic shear resistance under fire	See Annex C7

3.3 Health, hygiene and the environment (BWR 3)

Regarding dangerous substances contained in this UK Technical Assessment, there may be requirements applicable to the products falling within its scope (e.g. transposed UK legislation and national laws, regulations and administrative provisions). In order to meet the provisions of the Construction Products (Amendment etc.) (EU Exit) Regulations 2020, these requirements need also to be complied with, when and where they apply.

3.4 Safety and accessibility in use (BWR 4)

For Basic Requirement Safety in Use the same criteria are valid as for Basic Requirement Mechanical Resistance and Stability.

3.5 Protection against noise (BWR 5)

Not relevant.

3.6 Energy economy and heat retention (BWR 6)

Not relevant.

3.7 Sustainable use of natural resources (BWR 7)

Durability and Serviceability are only ensured if the specifications of intended use according to Annex B1 are kept.

4 Assessment and verification of constancy of performance (hereinafter AVCP) system applied

4.1 System of assessment and verification of constancy of performance

According to UKAD No. 330232-01-0601 and Annex V of the Construction Products Regulation (Regulation (EU) 305/2011 as brought into UK law and amended, the system of assessment and verification of constancy of performance (AVCP) 1 applies.

5 Technical details necessary for the implementation of the AVCP system, as provided for in the applicable UKAD

Technical details necessary for the implementation of the AVCP system are laid down in the control plan deposited with the British Board of Agrément and made available to the UK Approved Bodies involved in the conformity attestation process.

5.1 UKCA marking for the product/ system must contain the following information:

- Identification number of the Approved Body
- Name/address of the manufacturer of the product/ system
- Marking with intention of clarification of intended use
- Date of marking
- Number of certificate of constancy of performance (where applicable)
- UKTA number.

On behalf of the British Board of Agrément



Date of Issue: 12 October 2022

Hardy Giesler
Chief Executive Officer



British Board of Agrément,
1st Floor Building 3,
Hatters Lane,
Croxley Park
Watford
WD18 8YG

ANNEX A1

This annex applies to the product described in the main body of the UK Technical Assessment.

Liebig Superplus™ self-undercutting anchor

SD Type

Step Iron Anchor as per
DIN 1211-3 / DIN 1212-3

BLS Type

In-place installation

SLS Type

In-place installation

SKLS Type

In-place installation

BLS-P Type

Pre-positioned installation

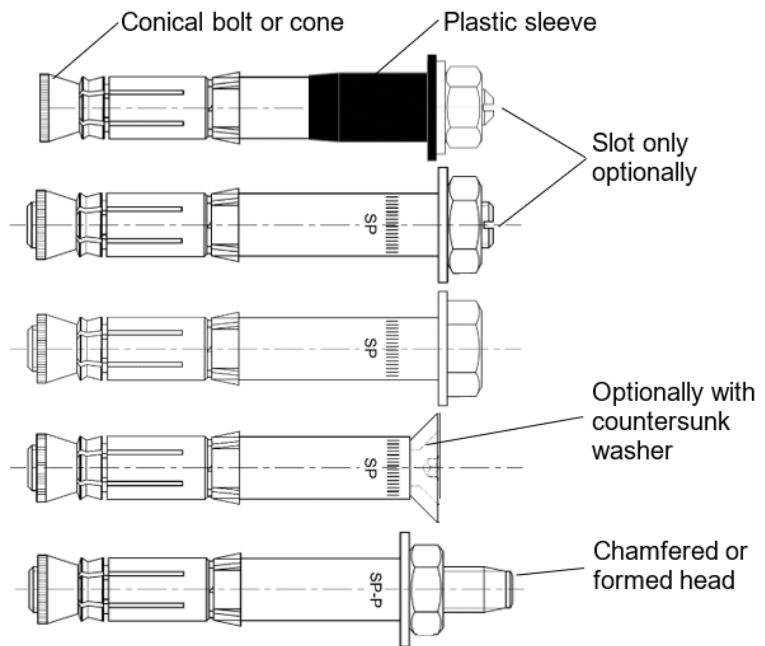

Marking:	Identifying mark:	⊗
	Anchor identity:	BLS; SLS; SKLS: e.g. SP M8 14/40/15 BLS-P: e.g. SP-P M8 14/40
	Setting depth marking:	knurl or groove
	Category	A4 or HCR (where applicable)

NOTE: The SD type corresponds to the BLS M8 A4 type with plastic sleeve surrounding the distance sleeve.

Liebig Superplus™ self-undercutting anchor after installation

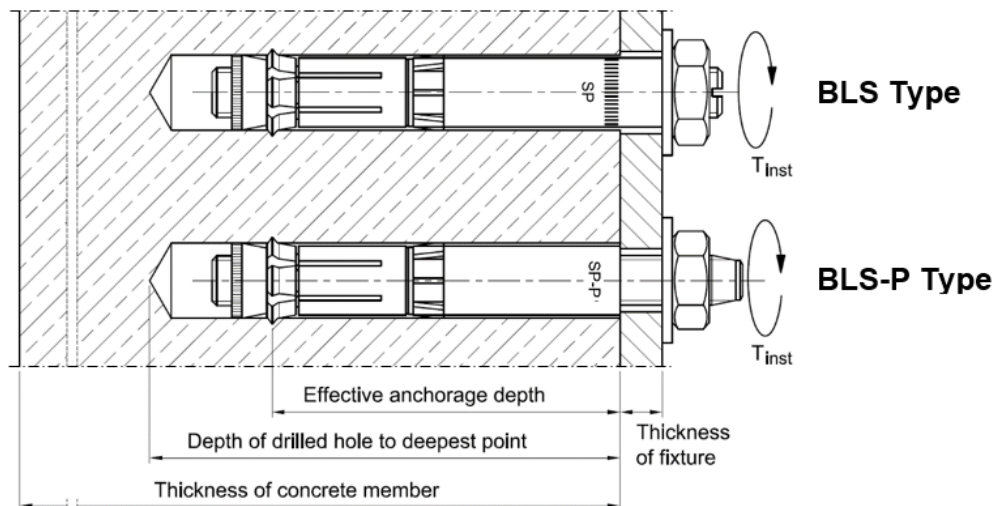

ANNEX B1

This annex applies to the product described in the main body of the UK Technical Assessment.

Liebig Superplus™ self-undercutting anchor

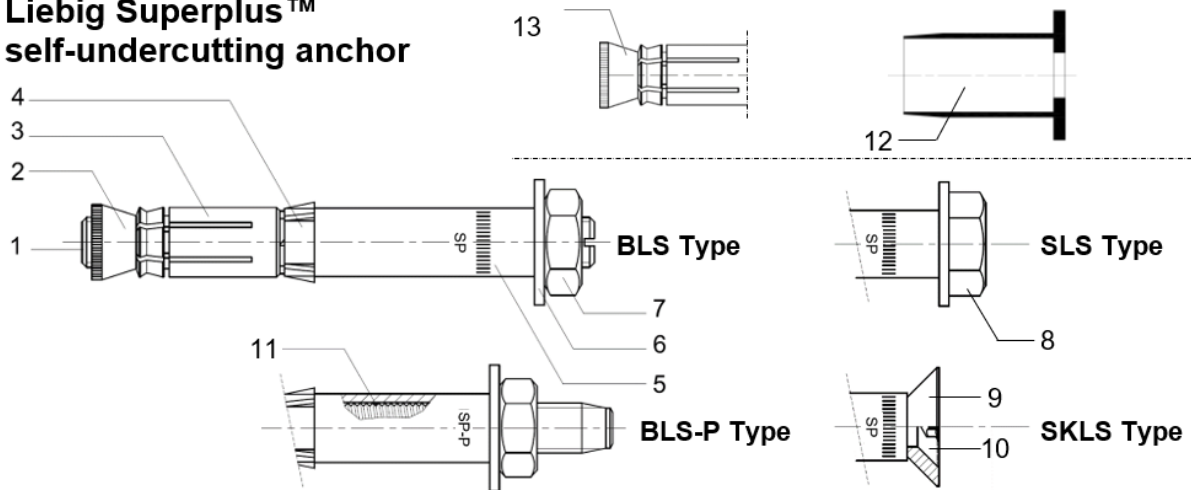

Table A1: Materials BLS, SLS, SKLS and BLS-P

Part	Designation	Material: Zinc electroplated ¹⁾
1	Threaded bolt	EN ISO 898-1; property class 8.8
2	Cone	Carbon steel
3	Anchor sleeve	Carbon steel
4	Plastic ring	PE
5	Distance sleeve	Carbon steel; $f_u \geq 500 \text{ N}\cdot\text{mm}^{-2}$
6	Washer	Carbon steel EN 10139
7	Hexagonal nut	EN ISO 898-2; property class 8
8	Hexagonal screw	EN ISO 898-1; property class 8
9	Countersunk washer	EN 10025: 1.0037 / EN 10087: 1.0718
10	Countersunk screw	EN ISO 898-1; property class 8
11	Grip (only BLS-P)	Drop of glue, tape or rubber O-Ring

(1) Coating: Parts 1 - 3 and 5 - 10 zinc electroplated according EN ISO 4042 $\geq 5\mu\text{m}$, passivated.

Table A2: Materials BLS, SLS, SKLS and BLS-P in A4/HCR and SD

Part	Designation	Material: Stainless steel A4/HCR
1	Threaded bolt	EN 10088: 1.4401 / 1.4404 / 1.4571 / 1.4529; EN ISO 3506-1: class 80
2	Cone	EN 10088: 1.4401 / 1.4404 / 1.4571 / 1.4529
3	Anchor sleeve	EN 10088: 1.4401 / 1.4404 / 1.4571 / 1.4529
4	Plastic ring	PE
5	Distance sleeve	EN 10088: 1.4401 / 1.4404 / 1.4571 / 1.4529; $f_u \geq 500 \text{ N}/\text{mm}^2$
6	Washer	EN 10088: 1.4401 / 1.4404 / 1.4571 / 1.4529
7	Hexagonal nut	EN 10088: 1.4401 / 1.4404 / 1.4571 / 1.4529; EN ISO 3506-2: class 80
8	Hexagonal screw	EN 10088: 1.4401 / 1.4404 / 1.4571 / 1.4529; EN ISO 3506-1: class 80
9	Countersunk washer	EN 10088: 1.4401 / 1.4404 / 1.4571 / 1.4529
10	Countersunk screw	EN 10088: 1.4401 / 1.4404 / 1.4571 / 1.4529; EN ISO 3506-1: class 80
11	Grip (only BLS-P)	Drop of glue, tape or rubber O-Ring
12	Plastic sleeve	PA; DIN EN ISO 1874-1
13	Conical bolt M8	EN 10088: 1.4401 / 1.4404 / 1.4571 / 1.4529; EN ISO 3506-1: class 80

SPECIFICATIONS OF INTENDED USE

Anchorage subject to:

- Static, quasi-static loads
- Fire exposure

<u>Zinc plated</u> - BLS, SLS, SKLS and BLS-P <u>Stainless Steel</u> - BLS, SLS, SKLS in A4 / HCR - BLS-P in A4 / HCR - SD (M8)	M8	14/40
		14/80
	M12	20/80
		20/150
	M16	25/150
		25/200

- Seismic actions for Performance Category C1 and C2

<u>Zinc plated</u> - BLS, SLS, SKLS and BLS-P	M12	20/80
		20/150
	M16	25/150
		25/200

Base materials:

- Cracked and Non-cracked concrete
- Reinforced or unreinforced normal weight concrete of strength classes C 20/25 at least to C50/60 at most according to EN 206

Use conditions (Environmental conditions):

- The BLS, SLS, SKLS and BLS-P anchors may only be used in structures subject to dry indoor conditions, indoor with temporary condensation.
- The BLS, SLS, SKLS in A4 and BLS-P in A4 may be used in concrete subject to dry internal conditions and also in concrete subject to external atmospheric exposure (including industrial and marine environment), or exposure in permanently damp internal conditions, if no particular aggressive conditions exist.
- The BLS, SLS, SKLS in HCR and BLS-P in HCR may be used in concrete subject to dry internal conditions and also in concrete subject to external atmospheric exposure, in permanently damp internal conditions or in other particular aggressive conditions.

Note: Particular aggressive conditions are e.g. permanent, alternating immersion in seawater or the splash zone of seawater, chloride atmosphere of indoor swimming pools or atmosphere with extreme chemical pollution (e.g. in desulphurization plants or road tunnels where de-icing materials are used).

ANNEX B2

This annex applies to the product described in the main body of the UK Technical Assessment.

Specifications of intended use

Design:

- The anchorages are designed in accordance with the EN 1992-4 *Design of fastenings for use in concrete* under the responsibility of an engineer experienced in anchorages and concrete work.
- For application with resistance under fire exposure the anchorages are designed in accordance with method given in EOTA TR 020 *Evaluation of Anchorage in Concrete concerning Resistance to Fire*.
- Verifiable calculation notes and drawings are prepared taking account of the loads to be anchored. The position of the anchor is indicated on the design drawings.

Installation:

- Anchor installation carried out by appropriately qualified personnel and under the supervision of the person responsible for technical matters of the site.
- Use of the anchor only as supplied by the manufacturer without exchanging the components of an anchor.
- Anchor installation in accordance with the manufacturer's specifications and drawings and using the appropriate tools.
- Effective anchorage depth, edge distances and spacing not less than the specified values without minus tolerances.
- Hole drilling by hammer drill.
- Cleaning of the hole of drilling dust
- BLS, SLS, SKLS and SD versions installed through fixture using an ordinary hammer and tightened to specified torque.
- BLS-P versions installed into drill-hole using an ordinary hammer. Then, nut and washer are removed, fixture installed, washer and nut installed, and tightened to specified torque.
- Application of specified torque moment using a calibrated torque tool

In case of aborted hole, drilling of new hole at a minimum distance of twice the depth of the aborted hole, or smaller distance provided the aborted drill hole is filled with high strength mortar and no shear or oblique tension loads in the direction of aborted hole

ANNEX B3

This annex applies to the product described in the main body of the UK Technical Assessment.

Liebig Superplus™ self-undercutting anchor

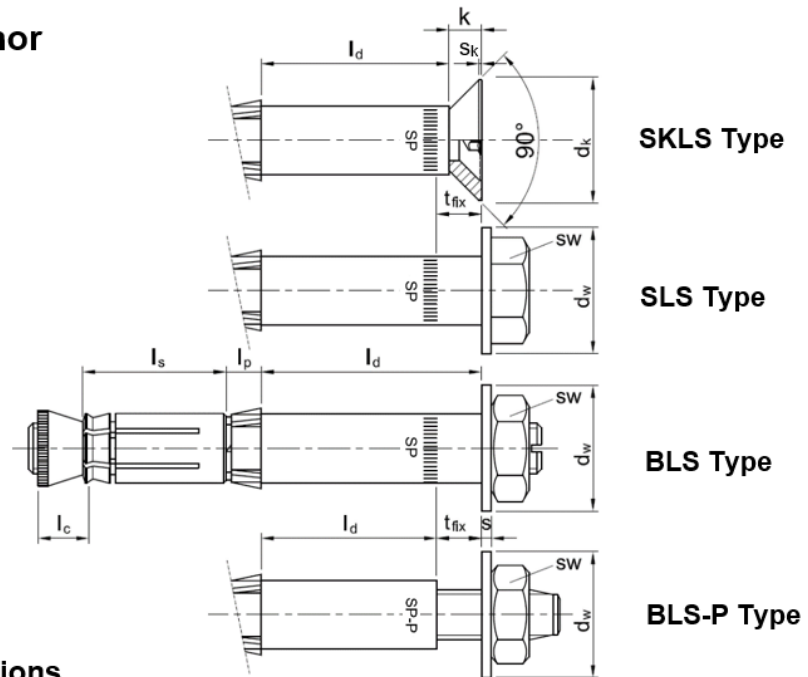

Table B1: Anchor dimensions

Main dimensions Anchor type	t _{fix} [mm]	Cone l _c [mm]	Sleeve l _s [mm]	Ring l _p [mm]	Distance l _d [mm]	Washer		CS head			Wrench ≥ SW [mm]
						≥ s [mm]	≥ d _w [mm]	d _k [mm]	k [mm]	s _k [mm]	
BLS, SLS, SKLS M8-14/40 (A4/HCR/SD)	0 - 100	11.8	26	6.0	9-109	1.5	20	24	6.5	0.5	13
2.5-102.5 (SKLS)											
BLS-P M8-14/40 (A4/HCR)					9						
BLS, SLS, SKLS M8-14/80 (A4/HCR/SD)	0 - 150	11.8	26	6.0	49-199	1.5	20	24	6.5	0.5	13
42.5-192.5 (SKLS)											
BLS-P M8-14/80 (A4/HCR)					49						
BLS, SLS, SKLS M12-20/80 (A4/HCR)	0 - 200	16.5	40	11.5	30-230	3.5	30	33	8.0	1.0	18
22-222 (SKLS)											
BLS-P M12-20/80 (A4/HCR)					30						
BLS, SLS, SKLS M12-20/150 (A4/HCR)	0 - 250	16.5	40	11.5	100-350	3.5	30	33	8.0	1.0	18
92-342 (SKLS)											
BLS-P M12-20/150 (A4/HCR)					100						
BLS, SLS, SKLS M16-25/150 (A4/HCR)	0 - 250	17.8	60	11.5	80-330	4.0	40	50	14.0	1.0	24
66-316 (SKLS)											
BLS-P M16-25/150 (A4/HCR)					80						
BLS, SLS, SKLS M16-25/200 (A4/HCR)	0 - 300	17.8	60	11.5	130-430	4.0	40	50	14.0	1.0	24
116-416 (SKLS)											
BLS-P M16-25/200 (A4/HCR)					130						

ANNEX B4

This annex applies to the product described in the main body of the UK Technical Assessment.

Liebig Superplus™ self-undercutting anchor

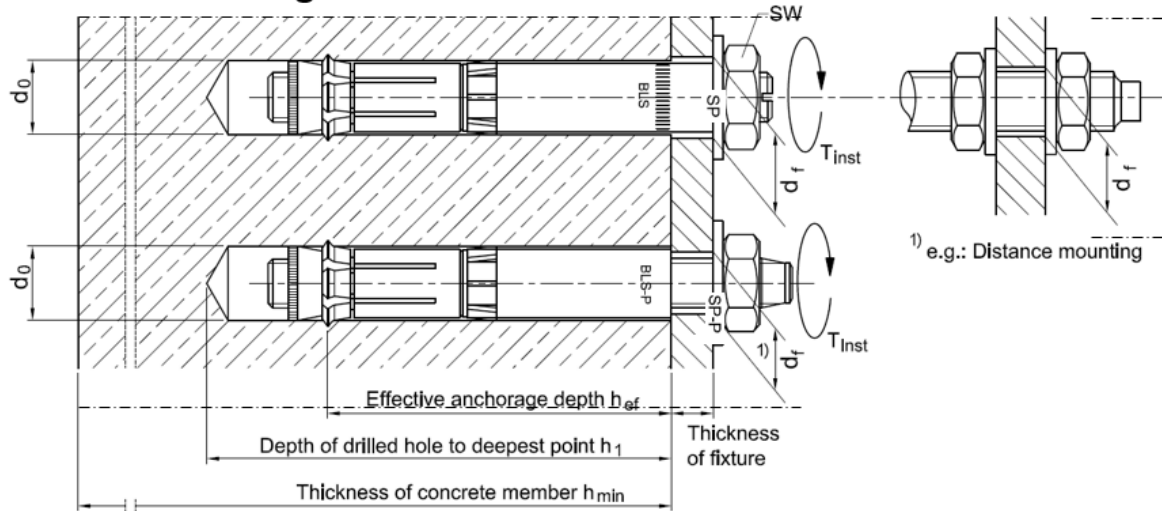

Table B2: Installation data

Zinc plated - BLS, SLS, SKLS - BLS-P		Stainless Steel - BLS, SLS, SKLS A4/HCR - BLS-P A4/HCR - SD (M8)		Anchor type					
				M8 - 14		M12 - 20		M16 - 25	
				/40	/80	/80	/150	/150	/200
Drill hole diameter		d_o	[mm]	14		20		25	
Cutting diameter at the upper tolerance limit (maximum diameter bit)		$d_{cut,max} \leq$	[mm]	14.50		20.55		25.55	
Depth of drilled hole to deepest point		$h_1 \geq$	[mm]	60	100	105	175	185	235
Effective anchorage depth		$h_{ef} \geq$	[mm]	40	80	80	150	150	200
Diameter of clearance hole in the fixture	In-place installation (BLS)	$d_f \leq$	[mm]	16		21		26	
	Mounting on the threaded bolt ¹⁾ (BLS-P / dist. mounting)	$d_f \leq$	[mm]	10		14		18	
Thickness of fixture		t_{fix}	[mm]	0-100	0-150	0-200	0-250	0-250	0-300
Width across flats BLS, SLS, BLS-P		SW	[mm]	≥ 13		≥ 18		≥ 24	
Width across flats / T- drive SKLS		SW / T-	[mm / -]	5 / 40		8 / ≥ 50		10 / ≥ 50	
Torque moment		T_{inst}	[Nm]	25		80		180	
Minimum thickness of concrete member		h_{min}	[mm]	100	160	160	300	300	400
Zinc plated	Minimum allowable spacing	s_{min}	[mm]	100	80	120	150	200	150
	Minimum allowable edge dist.	c_{min}	[mm]	80	50	100	80	150	100
Stainless steel / SD	Minimum allowable spacing	s_{min}	[mm]	80/110	80	150	150	150	180
	Minimum allowable edge dist.	c_{min}	[mm]	60/130	50	100	80	100	100

ANNEX C1

This annex applies to the product described in the main body of the UK Technical Assessment.

Table C1: Characteristic values for tension loads in case of static and quasi static loading.

Zinc plated - BLS, SLS, SKLS - BLS-P			Anchor type					
			M8 - 14 /40 /80		M12 - 20 /80 /150		M16 - 25 /150 /200	
Steel failure								
Characteristic resistance	$N_{Rk,s}$	[kN]	29.3		67.4		125.6	
Partial safety factor	$\gamma_{Ms}^{1)}$	[-]	1.5					
Pull-out failure								
Characteristic resistance in cracked concrete C20/25	$N_{Rk,p}$	[kN]	9	16	25	40	50	75
Characteristic resistance in non-cracked concrete C20/25	$N_{Rk,p}$	[kN]	not decisive failure mode					
Increasing factor for $N_{Rk,p}$	Ψ_C	C30/37	1.22					
		C40/50	1.41					
		C50/60	1.55					
Partial safety factor	γ_{inst}	[-]	1.0					
Concrete cone failure and splitting failure								
Effective anchorage depth	h_{ef}	[mm]	40	80	80	150	150	200
Factor for cracked concrete	$k_{cr,N}$	[-]	7.7					
Factor for non-cracked concrete	$k_{ucr,N}$	[-]	11.0					
Centre Spacing	$s_{cr,N}$	[mm]	120	240	240	450	450	600
Edge distance	$c_{cr,N}$	[mm]	60	120	120	225	225	300
Centre Spacing (splitting)	$s_{cr,sp}$	[mm]	140	360	360	540	560	560
Edge distance (splitting)	$c_{cr,sp}$	[mm]	70	180	180	270	280	280
Partial safety factor	γ_{inst}	[-]	1.0					

(1) In absence of other national regulations

ANNEX C2

This annex applies to the product described in the main body of the UK Technical Assessment.

Table C2: Characteristic values for tension loads in case of static and quasi static loading.

Stainless Steel - BLS, SLS, SKLS A4/HCR - BLS-P A4/HCR - SD (M8)			Anchor type						
			M8 - 14		M12 - 20		M16 - 25		
			/40	/40SD	/80	/80	/150	/150	/200
Steel failure									
Characteristic resistance	$N_{Rk,s}$	[kN]	29.3		67.4		125.6		
Partial safety factor	$\gamma_{Ms}^{1)}$	[-]	1.6						
Pull-out failure									
Characteristic resistance in cracked concrete C20/25	$N_{Rk,p}$	[kN]	9	12	25	40	60	60	
Characteristic resistance in non-cracked concrete C20/25	$N_{Rk,p}$	[kN]	not decisive failure mode						
Increasing factor for $N_{Rk,p}$	Ψ_C	C30/37	1.22						
		C40/50	1.41						
		C50/60	1.55						
Partial safety factor	γ_{inst}	[-]	1.0						
Concrete cone failure and splitting failure									
Effective anchorage depth	h_{ef}	[mm]	40	80	80	150	150	200	
Factor for cracked concrete	$k_{cr,N}$	[-]	7.7						
Factor for non-cracked concrete	$k_{ucr,N}$	[-]	11.0						
Centre Spacing	$s_{cr,N}$	[mm]	120	240	240	450	450	600	
Edge distance	$c_{cr,N}$	[mm]	60	120	120	225	225	300	
Centre Spacing (splitting)	$s_{cr,sp}$	[mm]	140	200	360	360	540	560	560
Edge distance (splitting)	$c_{cr,sp}$	[mm]	70	100	180	180	270	280	280
Partial safety factor	γ_{inst}	[-]	1.0						

(1) In absence of other national regulations

ANNEX C3

This annex applies to the product described in the main body of the UK Technical Assessment.

Table C3: Characteristic values for shear loads in case of static and quasi static loading

Zinc plated - BLS, SLS, SKLS - BLS-P				Anchor type					
				M8 - 14 /40 /80		M12 - 20 /80 /150		M16 - 25 /150 /200	
Steel failure without lever arm									
BLS	Characteristic resistance for In-place installation	$V_{Rk,s}$	[kN]	41.4		70.0		118.0	
	Partial safety factor	$\gamma_{Ms}^{1)}$	[-]	1.25					
BLS-P	Characteristic resistance for Pre-positioned installation	$V_{Rk,s}$	[kN]	15		34		63	
	Partial safety factor	$\gamma_{Ms}^{1)}$	[-]	1.25					
Factor for considering ductility		k_7	[-]	1.0					
Steel failure with lever arm									
Characteristic resistance		$M^0_{Rk,s}$	[Nm]	30		105		266	
Partial safety factor		$\gamma_{Ms}^{1)}$	[-]	1.25					
Concrete pry-out failure									
k-factor		k_8	[-]	1	2	2	2		
Partial safety factor		γ_{inst}	[-]	1.0					
Concrete edge failure									
Effective length of anchor under shear load		ℓ_f	[mm]	40	80	80	150	150	200
Outside diameter of anchor		d_{nom}	[mm]	14		20		25	
Cracked concrete without any edge reinforcement		$\Psi_{ucr,V}$	[-]	1.0					
Cracked concrete with straight edge reinforcement > Ø12 mm				1.2					
Cracked concrete with edge reinforcement and closely spaced stirrups ($a \leq 100\text{mm}$) or non-cracked concrete				1.4					
Partial safety factor		γ_{inst}	[-]	1.0					

(1) In absence of other national regulations

ANNEX C4

This annex applies to the product described in the main body of the UK Technical Assessment.

Table C4: Characteristic values for shear loads in case of static and quasi static loading

Stainless Steel - BLS, SLS, SKLS A4/HCR - BLS-P A4/HCR - SD (M8)				Anchor type					
				M8 - 14 /40 /80		M12 - 20 /80 /150		M16 - 25 /150 /200	
Steel failure without lever arm									
BLS	Characteristic resistance for In-place installation	$V_{Rk,s}$	[kN]	44.6		90.3		169.8	
	Partial safety factor	$\gamma_{Ms}^{1)}$	[-]	1.33					
BLS-P	Characteristic resistance for Pre-positioned installation	$V_{Rk,s}$	[kN]	15		34		63	
	Partial safety factor	$\gamma_{Ms}^{1)}$	[-]	1.33					
Factor for considering ductility		k_7	[-]	1.0					
Steel failure with lever arm									
Characteristic resistance		$M_{Rk,s}^0$	[Nm]	30		105		266	
Partial safety factor		$\gamma_{Ms}^{1)}$	[-]	1.33					
Concrete pryout failure									
k-factor		k_8	[-]	1	2	2		2	
Partial safety factor		γ_{inst}	[-]	1.0					
Concrete edge failure									
Effective length of anchor under shear load		l_f	[mm]	40	80	80	150	150	200
Outside diameter of anchor		d_{nom}	[mm]	14		20		25	
Cracked concrete without any edge reinforcement		$\Psi_{ucr,V}$	[-]	1.0					
Cracked concrete with straight edge reinforcement > Ø12 mm				1.2					
Cracked concrete with edge reinforcement and closely spaced stirrups ($a \leq 100\text{mm}$) or non-cracked concrete				1.4					
Partial safety factor		γ_{inst}	[-]	1.0					

(1) In absence of other national regulations

ANNEX C5

This annex applies to the product described in the main body of the UK Technical Assessment.

Table C5: Characteristic tension resistance under fire exposure

		<u>Zinc plated</u> - BLS, SLS, SKLS - BLS-P		<u>Stainless Steel</u> - BLS, SLS, SKLS A4/HCR - BLS-P A4/HCR - SD (M8)		Anchor size ($h_{ef,min}$)		
						M8 - 14/40	M12 - 20/80	M16 - 25/150
Steel failure								
Characteristic resistance $N_{Rk,s,fi}$	Zinc plated	R30	[kN]	0.37	1.70	3.10		
		R60	[kN]	0.33	1.30	2.30		
		R90	[kN]	0.26	1.10	0.84		
		R120	[kN]	0.18	0.84	1.60		
	Stainless steel	R30	[kN]	0.73	2.5	4.7		
		R60	[kN]	0.59	2.1	3.9		
		R90	[kN]	0.44	1.7	3.1		
		R120	[kN]	0.37	1.3	2.5		
Pull-out failure								
Characteristic resistance $N_{Rk,p,fi}$	Zinc plated	R30	[kN]	2.3	6.3	12.5		
		R60	[kN]	2.3	6.3	12.5		
		R90	[kN]	2.3	6.3	12.5		
		R120	[kN]	1.8	5.0	10.0		
Characteristic resistance $N_{Rk,p,fi}$	Stainless steel	R30	[kN]	2.3	6.3	15.0		
		R60	[kN]	2.3	6.3	15.0		
		R90	[kN]	2.3	6.3	15.0		
		R120	[kN]	1.8	5.0	12.0		
Concrete cone and splitting failure ¹⁾								
Characteristic resistance $N_{Rk,c,fi}$	R30	[kN]	1.8	10.3	49.6			
	R60	[kN]	1.8	10.3	49.6			
	R90	[kN]	1.8	10.3	49.6			
	R120	[kN]	1.5	8.2	39.7			
Spacing	$s_{cr,N,fi}$	[mm]	4 x h_{ef}					
	s_{min}	[mm]	80	150	150			
Edge distance	$c_{cr,N,fi}$	[mm]	2 x h_{ef}					
	c_{min}	[mm]	Fire attack from one side: $c_{min} = 2 \times h_{ef}$					
			Fire attack from more than one side: $c_{min} \geq 300 \text{ mm and } \geq 2 \times h_{ef}$					

(1) As a rule, splitting failure can be neglected when cracked concrete and reinforcement is assumed.

Design under fire exposure is performed according to the design method given in EOTA TR 020. Under fire exposure usually cracked concrete is assumed. The design equations are given in EOTA TR 020 section 2.2.1.

In the absence of other national regulations the partial safety factor for resistance under fire exposure $\gamma_{M,fi} = 1.0$ is recommended

ANNEX C6

This annex applies to the product described in the main body of the UK Technical Assessment.

Table C6: Characteristic tension resistance under fire exposure

				Anchor size ($h_{ef,max}$)		
				M8 - 14/80	M12 - 20/150	M16 - 25/200
Zinc plated		Stainless Steel				
- BLS, SLS, SKLS		- BLS, SLS, SKLS A4/HCR				
- BLS-P		- BLS-P A4/HCR				
		- SD (M8)				
Steel failure						
Characteristic resistance $N_{Rk,s,fi}$	Zinc plated	R30	[kN]	0.37	1.70	3.10
		R60	[kN]	0.33	1.30	2.30
		R90	[kN]	0.26	1.10	0.84
		R120	[kN]	0.18	0.84	1.60
	Stainless steel	R30	[kN]	0.73	2.5	4.7
		R60	[kN]	0.59	2.1	3.9
		R90	[kN]	0.44	1.7	3.1
		R120	[kN]	0.37	1.3	2.5
Pull-out failure						
Characteristic resistance $N_{Rk,p,fi}$	Zinc plated	R30	[kN]	4.0	10.0	18.8
		R60	[kN]	4.0	10.0	18.8
		R90	[kN]	4.0	10.0	18.8
		R120	[kN]	3.2	8.0	15.0
Characteristic resistance $N_{Rk,p,fi}$	Stainless steel	R30	[kN]	3.0	10.0	15.0
		R60	[kN]	3.0	10.0	15.0
		R90	[kN]	3.0	10.0	15.0
		R120	[kN]	2.4	8.0	12.0
Concrete cone and splitting failure ¹⁾						
Characteristic resistance $N_{Rk,c,fi}$	R30	[kN]	10.3	49.6	101.8	
	R60	[kN]	10.3	49.6	101.8	
	R90	[kN]	10.3	49.6	101.8	
	R120	[kN]	8.2	39.7	81.5	
Spacing	$s_{cr,N,fi}$	[mm]	4 x h_{ef}			
	s_{min}	[mm]	80	150	180	
Edge distance	$c_{cr,N,fi}$	[mm]	2 x h_{ef}			
	c_{min}	[mm]	Fire attack from one side: $c_{min} = 2 \times h_{ef}$ Fire attack from more than one side: $c_{min} \geq 300 \text{ mm and } \geq 2 \times h_{ef}$			

(1) As a rule, splitting failure can be neglected when cracked concrete and reinforcement is assumed.

Design under fire exposure is performed according to the design method given in EOTA TR 020. Under fire exposure usually cracked concrete is assumed. The design equations are given in EOTA TR 020 section 2.2.1.

In the absence of other national regulations the partial safety factor for resistance under fire exposure $\gamma_{M,fi} = 1.0$ is recommended

ANNEX C7

This annex applies to the product described in the main body of the UK Technical Assessment.

Table C7: Characteristic shear resistance under fire exposure

Zinc plated - BLS, SLS, SKLS - BLS-P		Stainless Steel - BLS, SLS, SKLS A4/HCR - BLS-P A4/HCR - SD (M8)		Anchor size		
				M8	M12	M16
Steel failure without lever arm						
Characteristic resistance $V_{Rk,s,fi}$	Zinc plated	R30	[kN]	0.37	1.7	3.1
		R60	[kN]	0.33	1.3	2.3
		R90	[kN]	0.26	1.1	2.0
		R120	[kN]	0.18	0.84	1.6
	Stainless steel	R30	[kN]	0.73	2.5	4.7
		R60	[kN]	0.59	2.1	3.9
		R90	[kN]	0.44	1.7	3.1
		R120	[kN]	0.37	1.3	2.5
Steel failure with lever arm						
Characteristic resistance $M^0_{Rk,s,fi}$	Zinc plated	R30	[Nm]	0.38	2.6	6.6
		R60	[Nm]	0.34	2.0	5.0
		R90	[Nm]	0.26	1.7	4.3
		R120	[Nm]	0.19	1.3	3.3
	Stainless steel	R30	[Nm]	0.75	3.9	9.9
		R60	[Nm]	0.60	3.3	8.3
		R90	[Nm]	0.45	2.6	6.6
		R120	[Nm]	0.38	2.1	5.3
Concrete pryout failure				M8 - 14/40	M12 - 20/80	M16 - 25/150
Factor in eq. (5.6) of ETAG Annex C, section 5.2.3.3		k	[-]	1	2	
Characteristic resistance $V_{Rk,cp,fi}$	R30	[kN]	1.8	20.6	99.2	
	R60	[kN]	1.8	20.6	99.2	
	R90	[kN]	1.8	20.6	99.2	
	R120	[kN]	1.5	16.4	79.4	
Concrete pryout failure				M8 - 14/80	M12 - 20/150	M16 - 25/200
Factor in eq. (5.6) of ETAG Annex C, section 5.2.3.3		k	[-]	2		
Characteristic resistance $V_{Rk,cp,fi}$	R30	[kN]	20.6	99.2	203.6	
	R60	[kN]	20.6	99.2	203.6	
	R90	[kN]	20.6	99.2	203.6	
	R120	[kN]	16.4	79.4	163.0	
Concrete edge failure						
The initial value $V^0_{Rk,c,fi}$ of the characteristic resistance in concrete C20/25 to C50/60 under fire exposure may be determined by:						
$V^0_{Rk,c,fi} = 0.25 \times V^0_{Rk,c} \quad (\leq R90) \qquad V^0_{Rk,c,fi} = 0.20 \times V^0_{Rk,c} \quad (R120)$						
with $V^0_{Rk,c}$ initial value of the characteristic resistance in cracked concrete C20/25 under normal temperature.						

Design under fire exposure is performed according to the design method given in EOTA TR 020.

Under fire exposure usually cracked concrete is assumed. The design equations are given in EOTA TR 020 section 2.2.1.

EOTA TR 020 covers design for fire exposure from one side. For fire attack from more than one side the edge distance must be increased to $c_{min} \geq 300$ mm and $\geq 2 \cdot h_{ef}$.

In the absence of other national regulations the partial safety factor for resistance under fire exposure $\gamma_{M,fi} = 1.0$ is recommended.

ANNEX C8

This annex applies to the product described in the main body of the UK Technical Assessment.

Table C8: Displacements under tension loads for static and quasi-static loading

Zinc plated - BLS, SLS, SKLS - BLS-P	Displacements and tensile loads in C20/25 to C50/60											
	Cracked concrete						Non-cracked concrete					
	C20/25			C50/60			C20/25			C50/60		
	N [kN]	δ_{N0} [mm]	$\delta_{N\infty}$ [mm]	N [kN]	δ_{N0} [mm]	$\delta_{N\infty}$ [mm]	N [kN]	δ_{N0} [mm]	$\delta_{N\infty}$ [mm]	N [kN]	δ_{N0} [mm]	$\delta_{N\infty}$ [mm]
M8 - 14/40	1.6	0.1	0.2	2.5	0.1	0.2	5.1	0.1	0.2	7.8	0.1	0.2
M8 - 14/80	5.9	0.2	0.4	15.1	0.2	0.4	10.8	0.2	0.4	15.1	0.2	0.4
M12 - 20/80	5.9	0.1	0.2	9.2	0.1	0.2	14.3	0.1	0.2	22.2	0.1	0.2
M12 - 20/150	15.9	0.2	0.5	39.7	0.2	0.5	28.4	0.2	0.5	39.7	0.2	0.5
M16 - 25/150	15.9	2.0	2.0	24.6	2.0	2.0	36.7	2.0	2.0	52.9	2.0	2.0
M16 - 25/200	29.8	2.0	2.0	74.1	2.0	2.0	52.9	2.0	2.0	74.1	2.0	2.0

Table C9: Displacements under tension loads for static and quasi-static loading

Stainless Steel - BLS, SLS, SKLS A4/HCR - BLS-P A4/HCR - SD (M8)	Displacements and tensile loads in C20/25 to C50/60											
	Cracked concrete						Non-cracked concrete					
	C20/25			C50/60			C20/25			C50/60		
	N [kN]	δ_{N0} [mm]	$\delta_{N\infty}$ [mm]	N [kN]	δ_{N0} [mm]	$\delta_{N\infty}$ [mm]	N [kN]	δ_{N0} [mm]	$\delta_{N\infty}$ [mm]	N [kN]	δ_{N0} [mm]	$\delta_{N\infty}$ [mm]
M8 - 14/40	3.6	0.3	1.1	5.5	0.3	1.1	3.4	0.2	0.6	5.5	0.1	0.6
M8 - 14/80	5.7	0.5	1.7	5.7	0.5	1.7	13.9	2.0	2.0	13.9	2.0	2.0
M12 - 20/80	9.9	0.5	0.9	15.4	0.7	0.9	14.3	0.4	0.6	32.1	1.0	1.0
M12 - 20/150	15.9	0.9	1.4	15.4	0.7	1.4	32.1	3.8	3.8	32.1	1.0	1.0
M16 - 25/150	23.8	0.9	1.4	36.9	1.4	1.4	36.7	0.7	0.7	59.8	3.4	3.4
M16 - 25/200	23.8	1.2	1.6	36.9	1.4	1.6	59.8	5.0	5.0	59.8	3.4	3.4

ANNEX C9

This annex applies to the product described in the main body of the UK Technical Assessment.

Table C10: Displacements under shear loads for static and quasi-static loading

Zinc plated - BLS, SLS, SKLS - BLS-P	Displacements and shear loads in C20/25 to C50/60					
	Cracked concrete C20/25 - C50/60			Non-cracked concrete C20/25 - C50/60		
	V	δ_{v0}	$\delta_{v\infty}$	V	δ_{v0}	$\delta_{v\infty}$
	[kN]	[mm]	[mm]	[kN]	[mm]	[mm]
M8 - 14/40	11.4	5.0 (+1.2)	7.5 (+1.2)	11.4	2.1 (+1.2)	3.1 (+1.2)
M8 - 14/80	11.4	5.0 (+1.2)	7.5 (+1.2)	11.4	2.1 (+1.2)	3.1 (+1.2)
M12 - 20/80	22.9	5.0 (+1.3)	7.5 (+1.3)	22.9	2.5 (+1.3)	3.8 (+1.3)
M12 - 20/150	22.9	5.0 (+1.3)	7.5 (+1.3)	22.9	2.5 (+1.3)	3.8 (+1.3)
M16 - 25/150	45.7	4.0 (+1.3)	6.0 (+1.3)	45.7	3.3 (+1.3)	5.0 (+1.3)
M16 - 25/200	45.7	4.0 (+1.3)	6.0 (+1.3)	45.7	3.3 (+1.3)	5.0 (+1.3)

Table C11: Displacements under shear loads for static and quasi-static loading

Stainless Steel - BLS, SLS, SKLS A4/HCR - BLS-P A4/HCR - SD (M8)	Displacements and shear loads in C20/25 to C50/60					
	Cracked concrete C20/25 - C50/60			Non-cracked concrete C20/25 - C50/60		
	V	δ_{v0}	$\delta_{v\infty}$	V	δ_{v0}	$\delta_{v\infty}$
	[kN]	[mm]	[mm]	[kN]	[mm]	[mm]
M8 - 14/40	25.5	6.3 (+1.7)	9.5 (+1.7)	25.5	6.3 (+1.7)	9.5 (+1.7)
M8 - 14/80	25.5	6.3 (+1.7)	9.5 (+1.7)	25.5	6.3 (+1.7)	9.5 (+1.7)
M12 - 20/80	51.6	8.0 (+1.7)	12.0 (+1.7)	51.6	8.0 (+1.7)	12.0 (+1.7)
M12 - 20/150	51.6	8.0 (+1.7)	12.0 (+1.7)	51.6	8.0 (+1.7)	12.0 (+1.7)
M16 - 25/150	96.5	8.8 (+1.7)	13.2 (+1.7)	96.5	8.8 (+1.7)	13.2 (+1.7)
M16 - 25/200	96.5	8.8 (+1.7)	13.2 (+1.7)	96.5	8.8 (+1.7)	13.2 (+1.7)

Displacement: the tables C10 and C11 show the deformation to be expected from the anchor itself, whilst the bracket value indicates the movement between the anchor body and the hole drilled in the concrete member or the hole in the fixture.

ANNEX C10

This annex applies to the product described in the main body of the UK Technical Assessment.

Table C12: Characteristic resistances in case of seismic action

Zinc plated - BLS, SLS, SKLS - BLS-P			Anchor size			
			M12-20		M16-25	
			/80	/150	/150	/200
Steel failure						
Characteristic resistance C1	$N_{Rk,s,seis,C1}$	[kN]	67.4	67.4	125.6	125.6
Characteristic resistance C2	$N_{Rk,s,seis,C2}$	[kN]	67.4	51.2	125.6	125.6
Partial safety factor	$\gamma_{Ms,seis}^{1)}$	[-]	1.5			
Steel failure without lever arm						
Characteristic resistance C1	$V_{Rk,s,seis,C1}$	[kN]	30.3		62.8	
Characteristic resistance C2	$V_{Rk,s,seis,C2}$	[kN]	18.2		51.5	
Partial safety factor	$\gamma_{Ms,seis}^{1)}$	[-]	1.25			
Pull-out failure						
Characteristic resistance C1	$N_{Rk,p,seis,C1}$	[kN]	25	40	50	50
Characteristic resistance C2	$N_{Rk,p,seis,C2}$	[kN]	25	40	50	50
Partial safety factor	$\gamma_{Mp,seis}^{1)}$	[-]	1.5 ²⁾			
Concrete cone and splitting failure³⁾						
Effective anchorage depth	h_{ef}	[mm]	80	150	150	200
Partial safety factor	$\gamma_{Mc,seis}^{1)}$ $\gamma_{Msp,seis}^{1)}$	[-]	1.5 ²⁾			
Concrete pryout and concrete edge failure³⁾						
Effective anchorage depth	h_{ef}	[mm]	80	150	150	200
Partial safety factor	$\gamma_{Mc,seis}^{1)}$	[-]	1.5 ²⁾			

(1) In absence of other national regulations

(2) The installation safety factor of $\gamma_2 = 1.0$ is included

(3) For concrete cone, splitting, pryout and edge failure, see EOTA TR 045

Table C13: Displacements in case of seismic action

Zinc plated - BLS, SLS, SKLS - BLS-P			Anchor size			
			M12-20		M16-25	
			/80	/150	/150	/200
Displacement DLS	$\delta_{N,seis}$	[mm]	4.6	7.3	7.2	7.2
Displacement ULS	$\delta_{N,seis}$	[mm]	9.2	13.1	10.9	10.9
Displacement DLS	$\delta_{V,seis}$	[mm]	6.2	6.2	5.6	5.6
Displacement ULS	$\delta_{V,seis}$	[mm]	10.9	10.9	11.1	11.1



British Board of Agrément,
1st Floor Building 3,
Hatters Lane,
Croxley Park
Watford
WD18 8YG